

# CHALWYN

World class manufacturer of safety solutions

IngWestad  
Distributor of industrial components



[www.ingwestad.no](http://www.ingwestad.no)



**Safety | Peace of Mind**



## Diesel Engine Safety Solutions

Product Selection Guide

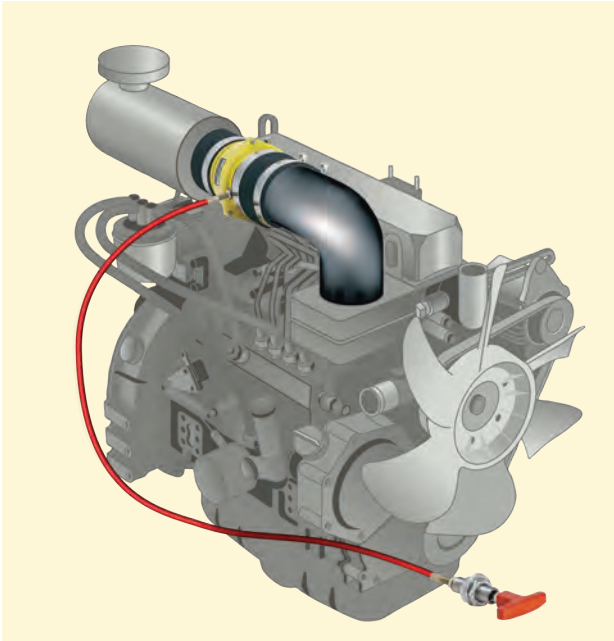

If flammable gas or vapour is drawn into the air intake of a diesel engine it acts as an additional uncontrolled fuel supply. This may result in uncontrolled engine overspeed followed by dangerous mechanical failure or flash back through the intake and the ignition of the surrounding gas or vapour cloud.

Once a flammable mixture is being drawn into the engine intake it may not be possible to stop the engine by closing down the fuel supply.

International standards and regulations in the oil and gas industry specify that an air intake shutdown valve must be fitted to ensure a guaranteed rapid and safe engine shut down.

## Popular applications for Chalwyn safety solutions

- Aerial Platforms
- Air Compressors
- Aircraft Refuelling
- Cranes
- Diesel Mowers
- Diggers
- Fuel Tankers
- Generator Sets
- Hydraulic Power Packs
- Jetting Pumps
- Light Towers
- Marine Engines
- Mining Machinery
- Mud Pumps
- Siesmic Testing Trucks
- Vacuum Trucks
- Vehicles
- Water Pumps
- Welding Sets
- Wire Line Units

## Contents

Automatic overspeed air intake shut down valves	3	Magnetic Pickups	9
Automatic overspeed and air pressure valves	4	Air pressure operated butterfly valves	10
Automatic overspeed and oil/air pressure valves	5	Electrically operated butterfly valves - failsafe	11
Typical full mechanical shut down control system	5	Hose kits	12
Fuel shut down valve	6	Exhaust spark arrestors	12
Mechanical overspeed valve and accessories	6	Flameproof alternators	13
Manual butterfly valves	7	Electrical sensors	13
Electrically operated butterfly valves	8	Electro-mechanical automatic shut down systems	14
Electronic speedswitch and accessories	9	System diagrams	15

## Additional information

To obtain copies of all Chalwyn publications listed in the following pages, please visit [www.chalwyn.com](http://www.chalwyn.com) and select: 'Documents/Installation, operation and maintenance'.

Alternatively please contact Chalwyn (see back cover) or your local distribution representative. These can be found on our website by selecting: 'Find local distributors'.

E-mail: [sales@chalwyn.com](mailto:sales@chalwyn.com)

## Automatic overspeed air intake shut down valves

Chalwyn D valves are the international industry standard for oil companies and operators for dependable engine shut down on overspeed. With patented air flow sensing design and lightweight construction they are easy to install and low maintenance.

### Basic D models

OVERSPEED TRIP ADJUSTER



HOSE ENDS  
(TO CUSTOMER REQUIREMENTS)

- Automatic reset after engine stops
- Tamper resistant speed adjuster
- Suitable for zone 1 or 2 installations
- No speed signal or power input needed
- 'Mini' range covers engine up to 27kW (36hp) and intake pipe diameters from 25mm (1 inch) to 58mm (2 1/4 inches)
- 'Bendix' range suits engines from 7.5kW (10hp) to 149kW (200hp) and intake hose bores from 40mm (1 9/16 inches) to 108mm (4 1/4 inches)
- Deutz special range valves are suitable for direct mounting to 1011 and 2011 naturally aspirated engines up to 53kW (72hp) and with 70mm (2 3/4 inches) standard inlet hose

### D-F models with integral air cleaner



OVERSPEED TRIP ADJUSTER  
UNDER AIR CLEANER COVER

- Combines with Chalwyn FSX-200 fuel shut down valve to give simultaneous shut down of intake air and diesel fuel supply (Bendix only)
- 'Spindle' range valves are suitable for engines with ratings from 80kW (107hp) to 392kW (525hp) and intake hose bores from 76mm (3 inches) to 153mm (6 inches)
- D200 range extends up to a maximum engine rating of 600kW (805hp) and intake hose bores between 152mm (6 inches) and 229mm (9 inches)

### D-AM models with remote manual stop

OVERSPEED TRIP ADJUSTER



CABLE (VARIOUS LENGTHS)

PULL STOP  
(LARGER VALVES HAVE  
DIFFERENT DESIGN  
STOP LEVER)

### DF-AM models with remote manual stop and an integral air cleaner

OVERSPEED TRIP ADJUSTER  
UNDER AIR CLEANER COVER



CABLE (VARIOUS LENGTHS)

PULL STOP T HANDLE

## Automatic engine air intake shut down valves with air pressure control

Air intake valves with automatic shut down on engine overspeed or on application of an air pressure signal for dependable engine shut down. With air flow sensing design and lightweight construction they are easy to install and low maintenance.

- Air flow sensing valves combining automatic overspeed shut down with air pressure operated shut down
- No speed signal or power input needed
- Automatic reset after engine shuts down and air pressure signal removed
- TPZ range suitable for engine ratings from 7.5kW (10hp) to 149kW (200hp) and intake hose bores from 51mm (2 inches) to 108mm (4 1/4 inches)
- Combines with Chalwyn FSX-200 fuel shut down valve to give simultaneous shut down of intake air and diesel fuel supply

### Basic TPZ models



### TPZ - AM models with manual shut down



- D-AP/ D-AMP valves can be selected to suit engine ratings from 80kW (107hp) up to 600kW (805hp) and engine air intake hose bores from 76mm (3 inches) to 229mm (9 inches)
- Suitable for zone 1 or 2 installations including air operated ESD systems

### Basic D-AP models

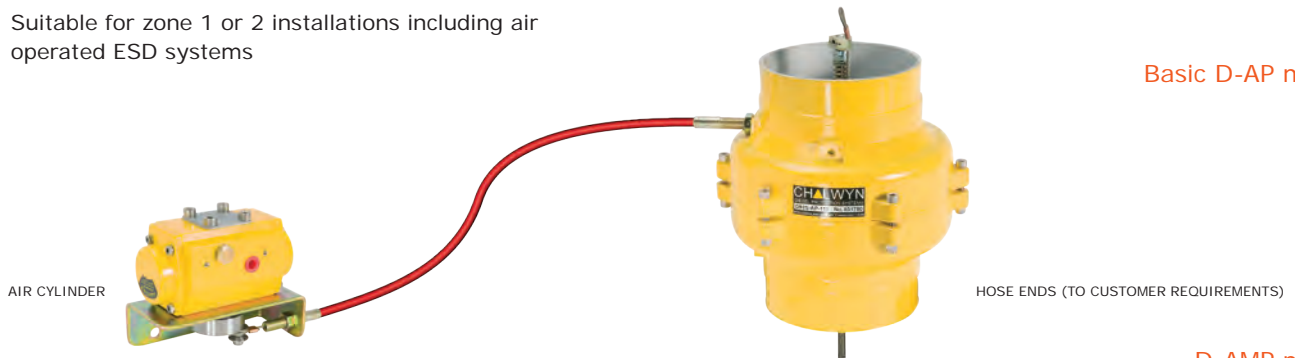

### D-AMP models with manual stop

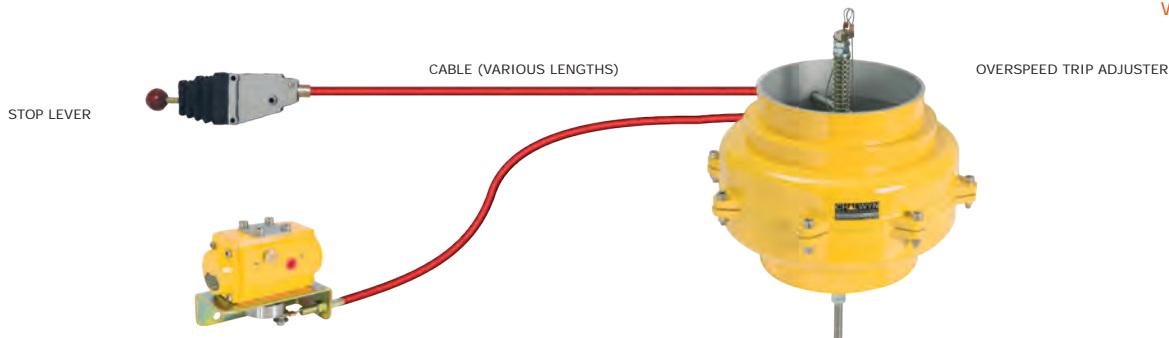

## Automatic engine air intake shut down valves with oil pressure control

Air intake valves with manual shut down combined with automatic shut down on overspeed or loss of oil (or air) pressure signal with air flow sensing design and lightweight construction they are easy to install and low maintenance.

### TMZ valves

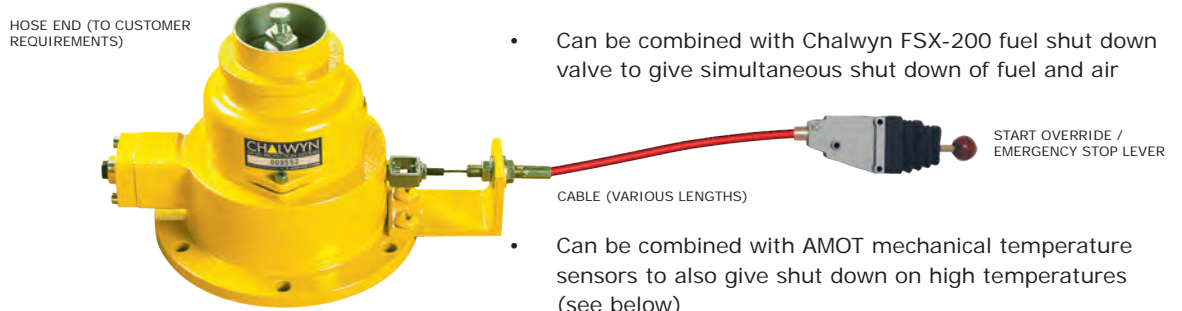

SMALLER TMZ VALVES HAVE FLAMETRAP HOUSING / FLANGED AIR OUTLET CONNECTION (NOTE HOSE ADAPTOR OPTION AVAILABLE)

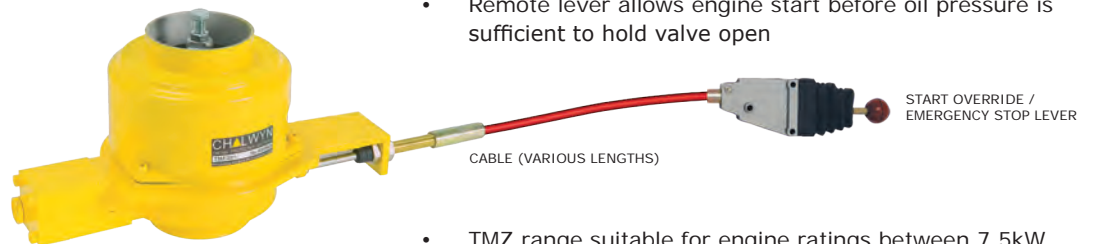

OIL (OR AIR) INPUT SIGNAL CONNECTION HOSE ENDS (BOTH ENDS OF LARGER VALVES)

- Dependable mechanical valve combining automatic overspeed shut down with shut down on loss of oil (or air) pressure and manual shut down by remote lever
- Can be combined with Chalwyn FSX-200 fuel shut down valve to give simultaneous shut down of fuel and air
- Can be combined with AMOT mechanical temperature sensors to also give shut down on high temperatures (see below)
- Models up to 93kW (125hp) are available with either outlet hose connection or flanged base with flametrap housing
- Remote lever allows engine start before oil pressure is sufficient to hold valve open
- TMZ range suitable for engine ratings between 7.5kW (10hp) and 149kW (200hp) and intake pipe bores between 40mm (1 9/16 inches) to 108mm (4 1/4 inches)
- Suitable for zones 1 and 2
- Zinc body versions available for mining use

### Typical TMZ valve installation

Example of arrangement to give manual shut down plus automatic shut down of both fuel and intake air on overspeed, low oil pressure and high coolant and exhaust gas temperatures.

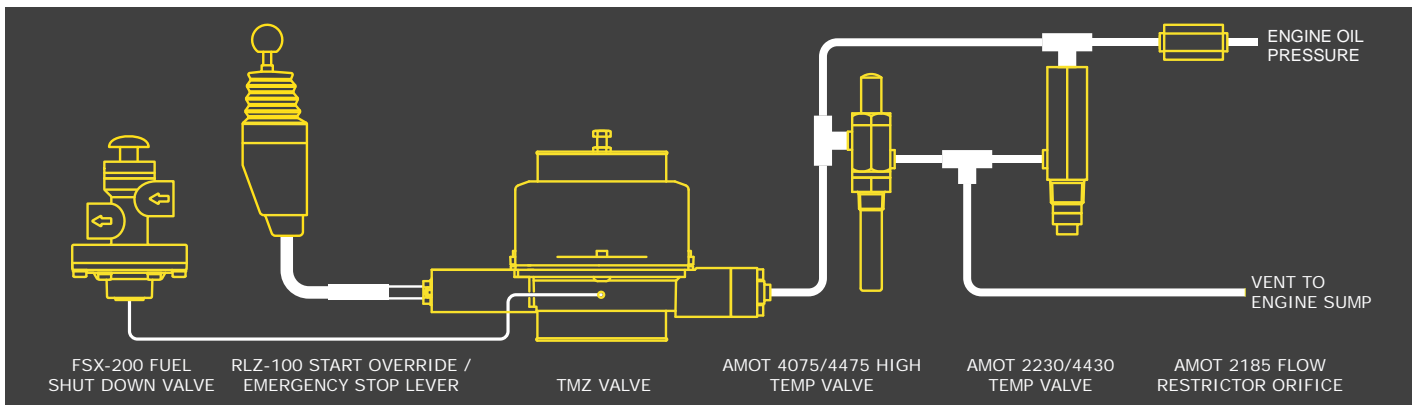

### D-AMZ valves

- D-AMZ range suitable for engine ratings from 80kW (107hp) up to 600kW (805hp) and engine air intake hose bores from 76mm (3 inches) to 229mm (9 inches)

## Air intake depression operated fuel shut down valve

The European standard EN 1834-1:2000 covering diesel engine operation in zone 1 or zone 2 hazardous areas where flammable gas or vapour may exist, requires that both the engine fuel and intake air supply are automatically shut down if engine overspeed occurs.

- Used in conjunction with Chalwyn air intake shut down valves
- Instant closure of fuel supply when intake valve shuts
- Does not require reset following a normal engine shut down
- Kits of parts available for the connection to the air intake valve
- Support bracket included

FSX-200

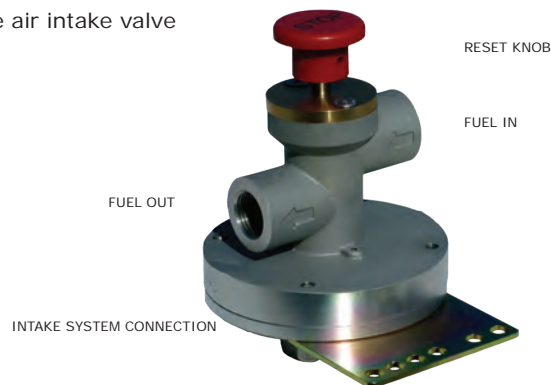

## Mechanical overspeed valve

AMOT 4110 overspeed valve

- Dependable mechanical protection from overspeed for engines and rotating equipment
- Available settings from 800 – 4200 RPM
- Trip point is field adjustable
- Operates in hydraulic or pneumatic systems
- Can be mounted in-line with existing tachometer cable
- Can be mounted in any position
- Several mounting extensions and adapters including flexible shafts and 90° cable drives available
- Anodised aluminium body construction



## Mechanical control system accessories

AMOT mechanical control system accessories are available for use in pneumatic or hydraulic engine control systems. Please contact the factory offices for more details.

AMOT 2230/4430 temperature sensor

AMOT 4155 temperature sensor

AMOT 4075/4475 temperature sensor

AMOT 2185 orifice

AMOT 4164 fuel valve

## Butterfly type engine air intake shut down valves

Manually operated air intake shut down valves are suitable for attended applications where automatic overspeed protection has not been specified. Their lightweight construction makes them easy to install with low maintenance.

### Basic MVX models



- Combination of body sizes and hose adaptors to suit air intake diameters from 38mm (1 1/2 inches) to 203 mm (8 inches)
- Simple operation – rapid engine shut down
- Push or pull shut down button on basic MVX valve
- Remote stop control by either push or pull options
- Can be flange or hose mounted
- Corrosion resistant, proven in offshore service
- Choice of cable lengths available
- Version with twin pull to stop cables available
- Choice of T handle or lever on pull to stop versions

### MVX models with remote stop control

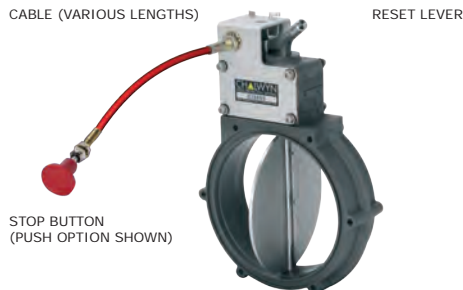

## Manually opened air intake valves with manual closure and automatic closure on loss of oil (or air) pressure signal HVX valves

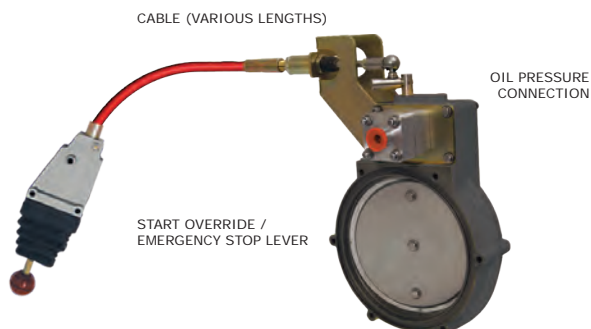

- Manually held open until oil (or air) pressure latches
- Direct acting remote manual emergency stop
- May be combined with AMOT mechanical sensors to give automatic shut down on high temperatures
- Combination of body sizes and hose adaptors to suit air intake diameters from 38mm (1 1/2 inches) to 152 mm (6 inches)

## Electrically operated valves - energised to close

Modern vehicles and industrial engines require compact low restriction air intake shutdown valves. Chalwyn offers an extensive range of butterfly valves to incorporate with automatic overspeed control systems.

- Compact design
- Suitable for vehicles and smaller engines
- 2 body sizes with choice of end diameters
- Range covers from 44mm (1 3/4 inches) to 77mm (3 inches)
- Manual reset control on valve
- Suitable for installation post-intercooler
- 12 volt and 24 volt versions
- Controlled by Chalwyn Revguard 2

SVR safe area energised to close models



### SVX valves

- Combination of body sizes and hose adaptors to suit air intake diameters from 38mm (1 1/2 inches) to 203 mm (8 inches)
- 12 volt or 24 volt versions
- Two wire solenoid connection
- Simple manual reset to latch open
- Manual cable option for secondary operation method or testing
- Internal micro switch option for valve status monitoring
- Versions available with hazardous area SSX solenoid
- Slim, lightweight, corrosion resistant construction
- Can be flange or hose mounted
- May be combined with Chalwyn FSX-200 fuel shut down valve to give simultaneous shut down of intake air and diesel fuel supply using FKX-300 fitting kit

SVX safe area energised to close models



STANDARD SOLENOID

RESET LEVER TO LATCH OPEN

OPTIONAL MANUAL CABLE MOUNTING BRACKET



## Electronic speed switch

Installations where butterfly valves are selected will require reliable sensing of the engine speed so that on detection of overspeed runaway the system will automatically signal the valve to close and safely stop the engine.

### Revguard 2



- Dependable protection from overspeed conditions on engines and other rotating equipment
- Monitors RPM by magnetic pick up
- Can also monitor alternator pulse signal output
- Trips when RPM exceeds desired set point
- Adjustable with 4 possible lower RPM test options
- 12 or 24 volt power source required
- Installation kits available to connect with butterfly valves
- Kit includes toggle switch, switch cover, relay, circuit breaker and LED status indicator light

## Magnetic pick ups

Chalwyn electronic speed switches are designed to sense the engine speed through either the alternator pulsation signal or a signal from a magnetic pick up that is positioned close to the flywheel ring gear.

### 4031 magnetic pick up



- Permanent magnet RPM sensor
- Fits in standard 3/4 inch UNF hole in flywheel housing
- Metric sizes also available
- Sends pulse signal to CSX-300 or Revguard 2
- 4031 is for general purpose use

### AMOT 8017B magnetic pick up



- AMOT 8017B is ATEX and CSA approved for hazardous areas

### SVA-200



- 24 volt air pressure solenoid powered to open
- Suitable for trucks with air pressure braking systems
- Allows air to flow to Chalwyn valve when powered
- Suits MPX, PVX and PVA valves
- Resets automatically on lose of signal from Revguard 2
- Simple plumbing using available fittings kit SKA-100

## Manual reset air intake shut down valve with air pressure or manual shut down

For larger trucks, trains and engines where air pressure is available, Chalwyn offer a wide range of butterfly valves which includes a choice of reset methods.

- Simple manual latch to open – air pressure releases valve to close and stop engine
- Manual shut down by valve mounted stop button or by cable from remote shut down control
- Push or pull remote shut down options with choice of cable lengths
- Suitable for drilling rig ESD (emergency shut down) air system installations
- Build option available without manual shut down
- Combination of body sizes and hose adaptors to suit air intake diameters from 38mm (1 1/2 inches) to 203 mm (8 inches)

MPX models



STOP BUTTON (VALVE MOUNTED OPTION)  
AIR PRESSURE CONNECTION  
RESET LEVER TO LATCH OPEN

## Air pressure operated intake shut down valves with automatic reset

- Simple direct air pressure operation
- Option to either open or close on the application of air pressure
- Automatic reset on loss of air pressure
- Valve status position visual indicator



POSITION INDICATOR  
AIR PRESSURE CONNECTION

PVX models

- Combination of body sizes and hose adaptors to suit air intake
- Diameters from 38mm (1 1/2 inches) to 203 mm (8 inches)

OPTIONAL HOSE ADAPTORS  
(ALL HVX, PVX, AND MPX VALVES)

PVX models

PVA models

- 71mm, 90mm and 140mm connection diameters offered
- Ultra slim design with integral hose ends

PVA models

All HVX, MPX and PVX valves

- Are of slim, lightweight, corrosion resistant construction
- Can be flange or hose mounted
- May be combined with Chalwyn FSX-200 fuel shut down valve to give simultaneous shut down of intake air and diesel fuel



POSITION INDICATOR  
AIR PRESSURE CONNECTION

CHOICE OF THREE HOSE  
CONNECTION DIAMETERS

## Electrically operated air intake shut down valves - energised to open

Chalwyn SVX butterfly valves are available with failsafe solenoid operation where the technical specification or EU ATEX Directive requires a control system that is powered to run whilst holding the shut down valve in the open position.

### SVX safe area energised to open models

STANDARD SOLENOID



- Externally switched 3 wire solenoids
- Automatic closure on loss of power - failsafe
- Internal micro switch option for valve status monitoring
- Combination of body sizes and hose adaptors to suit air intake diameters from 38mm (1 1/2 inches) to 203 mm (8 inches)
- Optional timer module SD-085 available

### SVX hazardous area energised to open models



EExe SOLENOID



OPTIONAL HOSE ADAPTORS  
(ALL SVX VALVES)

- ATEX approved for zone 1, IIB, T4 applications
- Externally switched 3 wire SSX solenoid with 3 core cable
- Automatic closure on loss of power - failsafe
- Combination of body sizes and hose adaptors to suit air intake diameters from 38mm (1 1/2 inches) to 203 mm (8 inches)
- Optional Timer Module available

### SVX energised to latch open models

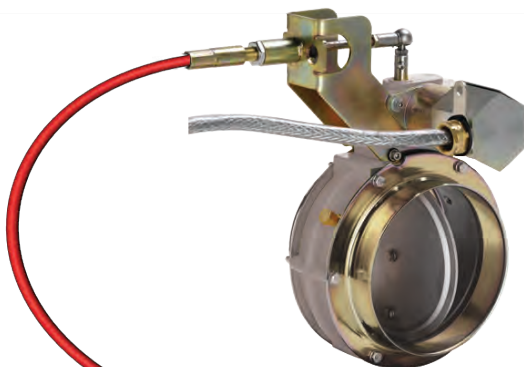

CABLE (VARIOUS LENGTHS)

START OVERRIDE /  
EMERGENCY STOP LEVER  
RLX-100

- ATEX approved for zone 1, IIB, T4 applications
- Two wire holding SSX solenoid with 2 core cable
- Safe are versions also available
- Manually held by remote lever for engine starting
- Sprung closed on loss of power
- Manual emergency stop
- Combination of body sizes and hose adaptors to suit air intake diameters from 38mm (1 1/2 inches) to 203 mm (8 inches)

## Hose kits

Whilst some valve installations can be made by cutting the original flexible hose, there are also many situations where a stronger silicon hose kit allows an easier installation to be made.

- High temperature silicone hose
- 2 clamps included
- Wide choice of popular sizes
- Suitable for both pre turbocharger and post turbocharger positions



## Exhaust spark arrestors

An exhaust spark arrestor is a key safety requirement for both hazardous areas and lower risk diesel engine applications such as refineries or gas plants where a stray spark may cause ignition of combustible hydrocarbons in the air.

Virtually all legislation for the use of diesel engines in hazardous areas includes a mandatory requirement to fit a certified exhaust spark arrestor.

- Ideal for offshore and corrosive environments
- ATEX compliant for surface and mining applications
- Certified for use in zone 1 and 2 areas
- 100% 316 grade stainless steel construction to EN1834 and ANSI standards
- Clamp-on pipe ends standard
- Threaded or flanged connections available to special order
- Range sizes covering engine ratings from 7.5kW (10hp) to 820kW (1100hp)
- Type SSE are non-silencing for end of line fitting on pipe sizes up to 102mm (4 inches) using single clamp included
- Type SSL have industrial standard silencing so can replace vehicle silencers or for supported installation with pipe sizes up to 254mm (10 inches)
- Pipe adaptor tubes available

Spark arrestors

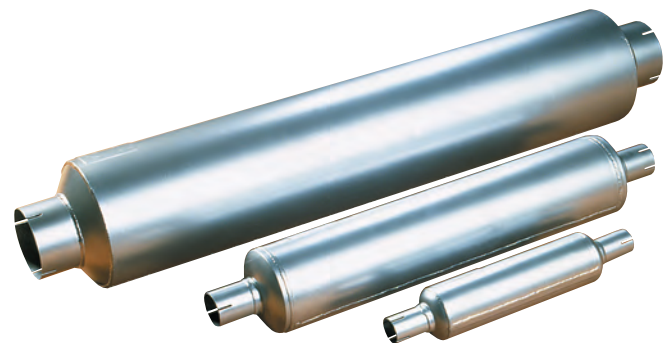

## Flameproof alternators

Standard automotive alternators are a continuous potential source of ignition when fitted to an engine operating in a hazardous area where combustible concentrations of gas, vapour or dust may exist. Always replace with a suitable flameproof type when operating in defined hazardous zones.

- Exd IIB T4 ATEX compliant variants applicable to Group II hazardous gas, vapour and Group III dust applications
- Certified to IECEx Standards (not ASX-400/1)\*
- Certified to NEC 505 Zone 2 (not ASX-400/1)\*
- Certified to NEC 500 (not ASX-400/1) & NEC 506 (ASX-405/6 only)\*
- Some models certified to Canadian CSA Standards\*
- Standard automotive internal regulation
- Wide choice of drive pulley options
- Speed signal output
- Optional gland positions for ease of installation
- Outputs – Group II Types:

ASX-200: 12 volts / 50 amperes  
 ASX-300: 24 volts / 25 amperes  
 ASX-310: 24 volts / 25 amperes  
 ASX-400: 24 volts / 50 amperes  
 ASX-405: 24 volts / 50 amperes

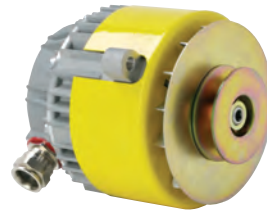

Battery excited types  
ASX-200 and ASX-300



Self exciting types  
ASX-310



High output battery excited types  
ASX-405



## Electrical switch type sensors

In order to provide complete shut down control systems for engines operating in hazardous areas, Chalwyn and AMOT offer a range of electrical sensors.

### TSX coolant temperature sensor



- Suitable for incorporation into Chalwyn Series 110, 111, 210 and 300 electro-mechanical systems

- Twin 4m long flying leads
- Electrically isolated cases
- Corrosion resistant construction

### TSX exhaust temperature sensor



- Gold or fine silver contacts
- Standard factory setting for coolant temperature sensor 100°C (212°F)

### PSX pressure sensor



- Standard factory settings for exhaust temperature sensors 135°C (275°F), 150°C (302°F) and 200°C 392°F)
- Standard factory setting for oil pressure sensor 0.7 bar (10psi) falling

## Electro-mechanical automatic shut down systems

In addition to automatic shut down of engine intake air and fuel on overspeed, flameproof requirements for diesel engines operating in hazardous areas also usually require engine shut down on low engine oil pressure, high coolant and high exhaust temperatures.

### Self contained zone 1 hazardous area electro-mechanical shut down systems

Series 110 and  
Series 111 systems



- Automatic shut down on overspeed, low oil pressure and up to four temperature settings
- Responds to 'rig yellow' alert or 'gas detection' input shut down signals
- Direct manual shut down control
- Precision overspeed trip speed setting via simple press button
- Simultaneous shut down of both intake air and fuel
- May be installed and operated completely independently of other engine systems
- No battery/power input required
- Speed signal generated by system alternator ASX-310
- Useful output of 24 volts / 20 amperes available
- Only powered when engine is running
- ATEX / EMC compliant system
- Series 111 version drives two intake shut down valves
- Fail safe design as required by EN 1834 standards

### Zone 1 hazardous area systems for integration with other engine systems

Series 210 systems



- Automatic shut down on overspeed, low oil pressure and up to four temperature settings
- Responds to 'rig yellow' alert or 'gas detection' input shut down signals
- Precision overspeed trip speed setting via simple press button
- Simultaneous shut down of both intake air and fuel control
- Speed signal generated by system alternator
- EExe alternator output available for battery charging etc.
- Run/stop signal from control unit may be used to control EExe solenoid operated or pneumatically operated intake and fuel shut down valves
- ATEX / EMC compliant components
- Options to suit either 12 volt or 24 volt battery
- Fail safe design as required by EN 1834 standards

### Added safety shut down systems (non-failsafe)

Series 300 systems

- Suitable for vehicles and engine applications not requiring hazardous area compliant equipment
- Automatic intake valve shut down on overspeed
- 12 volt (CSX-300) or 24 volt (CSX-310) systems
- Integral relay for direct connection to SVX and SVR range valves
- Optional sensor circuit (CSX-301 or CSX-311) versions for shut down on low oil pressure and up to four temperature settings
- Can be tripped by gas detector added to normally closed sensor circuit
- Precision overspeed trip speed setting via simple press button
- Speed signal input from existing alternator or flywheel magnetic pick up
- IP rated weather resistant metal enclosure
- Manual remote shut down button CSX-840
- System status LED on CSX-840

## Electro-mechanical automatic shut down systems

### Typical Series 110 installation

Arrangement to give automatic air and fuel shut down on engine overspeed, low oil pressure, high coolant and exhaust temperatures and on a shut down signal from a gas detection system.

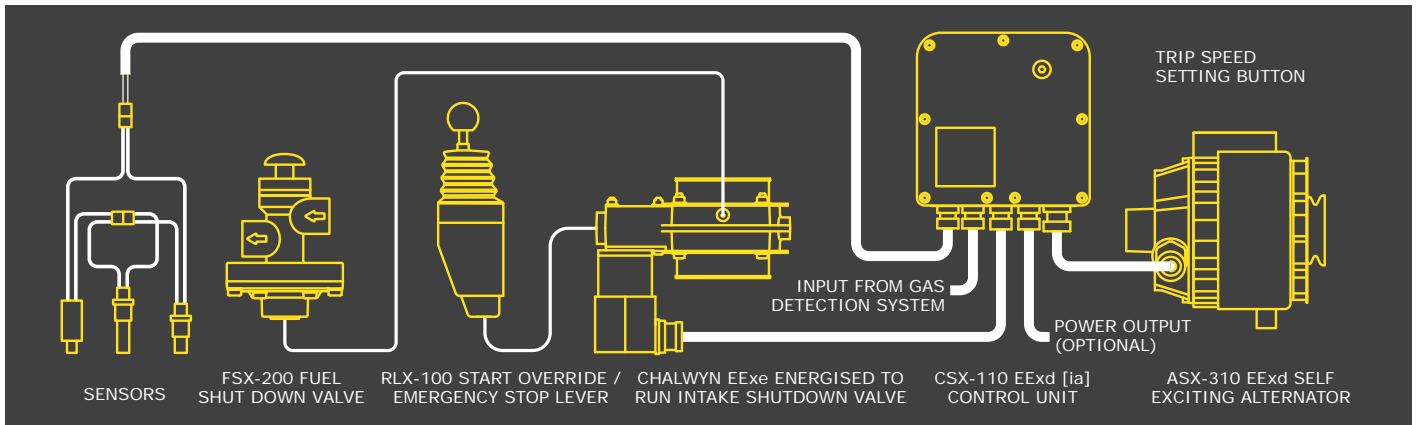

### Typical Series 210 installation

Arrangement to give automatic air and fuel shut down on engine overspeed, low oil pressure, high coolant and exhaust temperatures and on a rig 'yellow alert' signal.

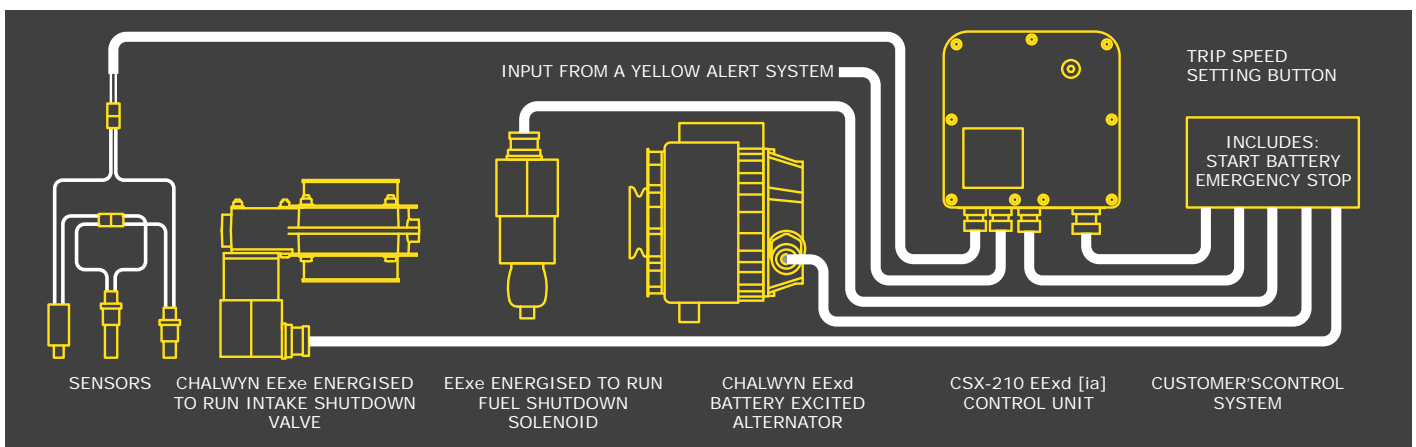

### Typical Series 300 installation

Arrangement to give automatic intake air shut down on engine overspeed, low oil pressure and high coolant temperature with remote manual stop control.

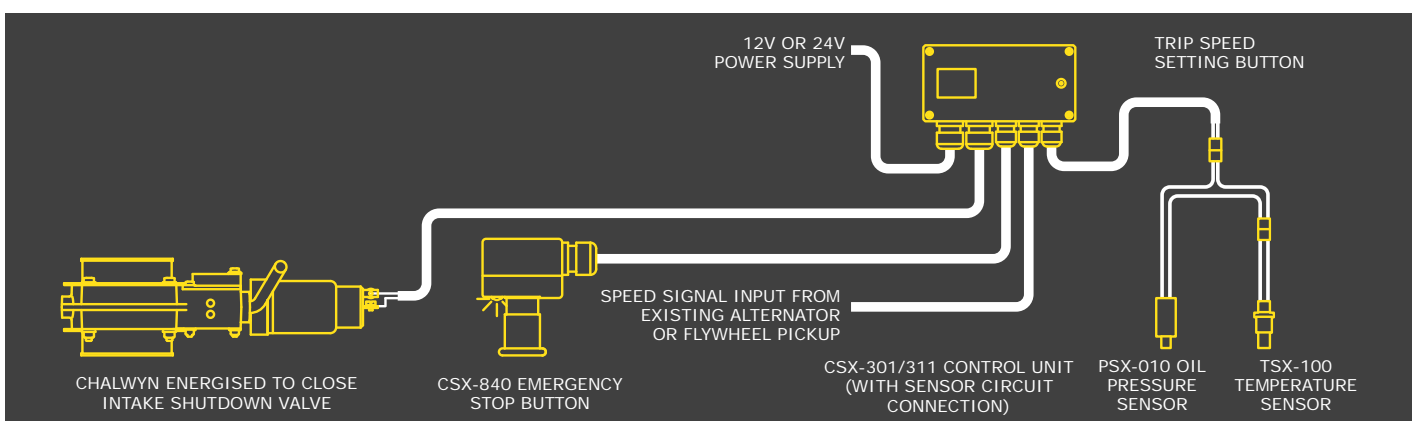

Chalwyn has more than 40 years of experience and is the industry leader in manufacturing engine safety shut down valves to support the oil and gas industry. We have worldwide sales offices with manufacturing facilities in England, Canada and the United States to serve our global markets.

Our broad range of engine safety solutions include AMOT, Roda Deaco and Chalwyn brands. To find your nearest distributor for Diesel Engine Safety Solutions, visit the home page of our website and select "Find Local Dist".

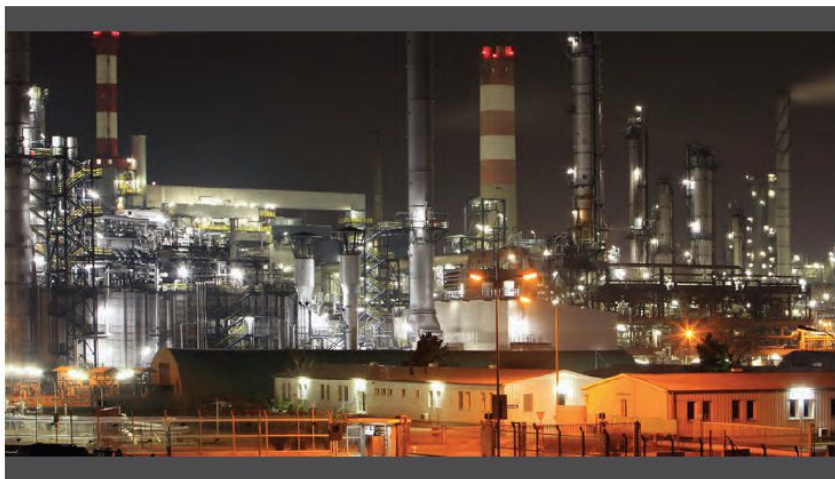

Contact our sales office below for more information.

# IngWestad

Distributor of industrial components



Ing. Westad AS  
Nesbruveien 82  
1394 Nesbru

Tlf 66 84 66 67  
post@ingwestad.no  
www.ingwestad.no

## CHALWYN

[www.chalwyn.com](http://www.chalwyn.com)

Chalwyn's Quality  
Management System  
is approved by LRQA.

